

MATHEMATICAL MODELING OF EMOTIONAL BRAIN FOR CLASSIFICATION PROBLEMS

Ehsan Lotfi¹

¹Department of Computer Engineering, Torbat-e-Jam Branch, Islamic Azad University,
Torbat-e-Jam, Iran,
e-mail: esilotf@gmail.com

Abstract. Recently various models of mammalian's brain emotional learning (BEL) have been successfully utilized in specific control applications and prediction problems. In this paper, a BEL based classifier (BELC) is presented. The distinctive feature of BELC is applying the activation function *tansig* in the model. In the numerical studies, various comparisons are made between BELC and multilayer perceptron (MLP) to classify 6 UCI datasets. According to the numerical studies, BELC shows higher accuracy and lower computational complexity in single class classification and can be utilized in real time classification problems.

Keywords: Amygdala, computational model, BELBIC, online classification.

AMS Subject Classification: 93A30.

1. Introduction

The Environment around us involves various objects and schemas. Through watching, experiencing and sensing, humans are able to learn patterns and consequently recognize, predict and make decision based on them. Learning is mental phenomenon and according to the cognitive studies can be reinforced in the amygdala area of the brain with external reward or punishment received from various real-life situations (from the outer world) [1]. The amygdala is part of the limbic system (LS) [2] which based on the brain emotional learning (BEL) creates emotional intelligence. See Fig. 1, the LS is located in the cerebral cortex and consists of the following components [3]: Amygdala, Orbitofrontal Cortex (OFC), Thalamus, Sensory Cortex, Hypothalamus and Hippocampus. Amygdala is located in sub-cortical area and associated with several cognitive functions including: permanent memory, managing emotional stimuli [4, 5] and the conditioning experiments [6]. Amygdala receives plastic connections from sensory cortex and thalamus and the internal reinforcer caused by external reward and punishment [7]. It also interacts with the OFC. Amygdala responds to emotional stimulus. OFC tries to inhibit inappropriate Amygdala answers based on the context given by the hippocampus [7]. OFC also receives plastic connections from sensory cortex and there is no connection between OFC and thalamus [7].

Recently several mathematical computational models of LS are proposed by researchers. The first applied amygdala-OFC model was proposed by Morén and

Balkenius [7-8]. The model in Fig. 2 learns to react to the new stimulus based on a history of input rewards and punishment signals. Additionally, in the model, the amygdala learns to respond to emotional stimuli. And the OFC inhibits inappropriate experiences and learning connections. In the model, the reward signal was not clearly defined and this signal was vital for updating the weights of

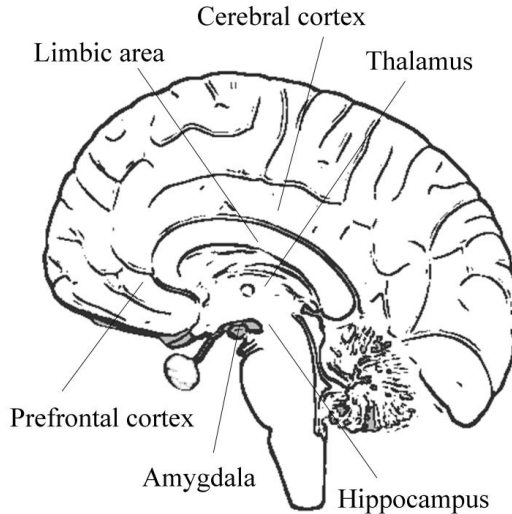

Fig. 1. The limbic system in the brain.

subsystems. Lucas et al. [9-10] explicitly determined the reward signal and proposed the BEL base controller which has been successfully modified and utilized in various control applications [11-18] and prediction problems [19-22]. Babaei et al. [23] formulized the input reward for multi agent optimization problems and presented a BEL based predictor in an alarm system for satellites. The predictor results provided by Babaei are dependent on the model and cannot be generalized to other issues. In this paper, a novel classifier based on BEL is proposed. In contrast to reviewed BEL models, the proposed method can be used in classification problems. The proposed method is general and can be examined in various fields such as emotion recognition and expression [24-27], emotion-cognition modeling [28-29], and autonomous agents designing [30-34]. The paper is organized as follows: the proposed method is presented in Sections 2. Section 3 presents the numerical results where the proposed method is compared with backpropagation multilayer perceptron (MLP). There are various versions of backpropagation algorithm; the gradient descent backpropagation (GDBP) [35], which is the standard basic algorithm, is utilized. And finally conclusions are made in Section 4.

2. Proposed Brain Emotional Learning based Classifier

Here we propose BEL based classifier (BELC) which can be used for single class classification problems. In contrast to previous BEL based models, proposed method can be used in classification problems. This ability is created by using an activation function. Actually, the main modification introduced here with respect to the common BEL based models is applying an activation function on the amygdala

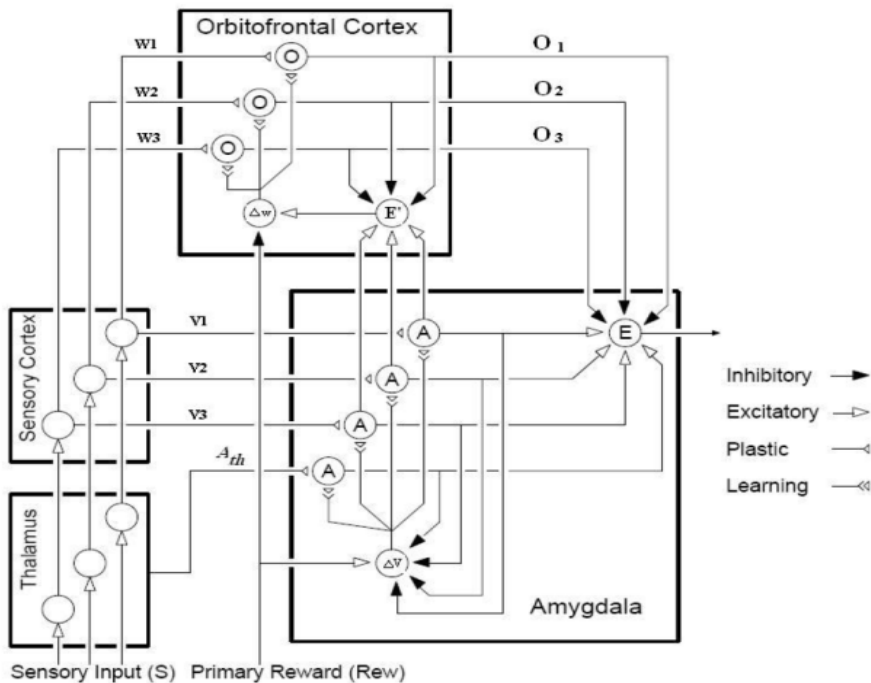

Fig. 2. The amygdala-OFC model proposed by Morén and Balkenius [7, 8].

output. Fig. 3 shows the proposed model, where the solid lines present the data flow and learning lines are presented by dashed lines. In Fig. 3, the model is presented as n inputs–single output architecture. The input pattern is illustrated by vector $p_{0 < j < n+1}$ and the E is the final output. The model consists of two main subsystems including amygdala and the OFC. The amygdala receives the input pattern including: p_1, p_2, \dots, p_n from sensory cortex, and p_{n+1} from the thalamus, while the OFC receives the input pattern including p_1, p_2, \dots, p_n from the sensory cortex only. The p_{n+1} calculated by following formula is the output of thalamus and one of amygdala inputs:

$$p_{n+1} = \max_{j=1..n}(p_j). \quad (1)$$

And v_{n+1} is related amygdala weight. The E_a is internal output of amygdala that is used for adjusting the plastic connection weights v_1, v_2, \dots, v_{n+1} and E_o is output of OFC that is used for inhabiting the amygdala output. This inhibitory task is implemented by subtraction of E_o from E_a (see Eq. 5). E as corrected amygdala response is final output node and evaluated by monotonic increasing activation function *tansig* and is used to adjust OFC connection weights including w_1, w_2, \dots, w_n . The activation function is as follows:

$$\text{tansig}(x) = \frac{2}{1 + e^{-2x}} - 1. \quad (2)$$

And the amygdala, OFC and final output are simply calculated by following formulas respectively:

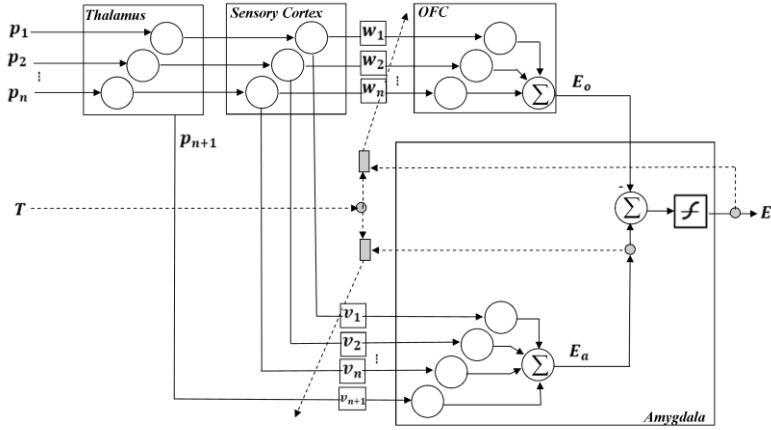

Fig. 3. Proposed computational model for Limbic system.

$$E_a = \sum_{j=1}^{n+1} (v_j \times p_j). \quad (3)$$

$$E_o = \sum_{j=1}^n (w_j \times p_j). \quad (4)$$

$$E = \text{tansig}(E_a - E_o). \quad (5)$$

The model also needs a target associated to input pattern to adjust the weights. Let T^k be target value associated to k th pattern (p^k). So the supervised learning rules are as follows:

$$v_j^{k+1} = (1 - \gamma)v_j^k + \alpha \max(T^k - E_a^k, 0)p_j^k \quad (6)$$

$$w_j^{k+1} = w_j^k + \beta(E^k - T^k)p_j^k \quad (7)$$

Where k is learning step, α and β are learning rates and γ is decay rate in amygdala learning rule, where the *max* operator causes the monotonic learning, i.e. ones an input pattern is learned, it cannot be unlearned. Actually, the permanent memory cognitive function of amygdala is done.

The proposed structure can be used in single-class classification problems where the number of attributes in the input pattern determines the number of neurons in the thalamus, sensory cortex, amygdala and OFC. And target T is labeled by 0 or 1.

3. Experimental Results

To evaluate the BELC in the classification problems, accuracy and mean square error (MSE) are performance measures that are generally expressed as follows:

$$Accuracy = \frac{Correct\ Detection}{All}, \quad (8)$$

$$MSE = \frac{1}{n} \sum_{i=1}^n (E_i - T_i)^2, \quad (9)$$

where E_i is output of i th input pattern and T_i is its target. For all the learning scenarios listed below, the training set contained 70% while the testing set contained 15% of the data and the remaining data was used for the validation set. The initial weights of v are randomly selected between [0,1]. They are multiplied by -1 and the results are used as the initial weights of w . To test and assess the proposed algorithm, 6 single class data sets have been downloaded from UCI Data Center. In all datasets, the target labeling is binary. Table 1 shows the information related to the data sets that includes the number of attributes and instances. Additionally, the learning parameters values are presented in the Table 1. The stop criterion in learning process was the maximum epochs, which means the maximum number of epochs has been reached. The maximum and minimum values of each pattern set were determined and the scaled data (between 0 and 1) were used to adjust the weights. The training was repeated 10 times and the average of accuracy in test set was recorded. Table 2 presents the accuracy average and the confidence interval obtained from BELC and MLP. It's obvious that BELC is more accurate than MLP in 10, 100 epochs. In Table 2 bold the entries suggests that the improvement in the BELC was statistically significant. The results indicated in Table 2 are based on student's t -test with 95% confidence.

Table 1. Datasets and related learning information.

Name	Instance	Class	Attribute	Learning	Decay
Diabetes	768	2	8	0.050	0.010
Heart	270	2	13	0.050	0.010
Pima	768	2	8	0.005	0.001
Ionosphere	351	2	34	0.050	0.010
Sonar	208	2	60	0.0005	0.001
Tic-tac	958	2	9	0.0005	0.001

Table 2. The average accuracy of classification results obtained from BELC and MLP during 10 runs.

<i>epochs</i>	10		100		1000		10000	
	BELC	MLP	BELC	MLP	BELC	MLP	BELC	MLP
Diabetes	68.96±4.46	58.28±12.64	71.39±2.50	66.61±5.42	69.91±3.04	76.61±3.54	71.74±3.01	76.61±3.54
Heart	57.90±6.58	58.29±8.88	66.10±6.78	76.59±5.04	64.15±8.23	81.22±5.28	76.07±5.25	81.22±5.28
Pima	67.65±1.26	53.04±10.48	68.78±2.86	61.48±6.84	74.08±3.73	75.65±2.91	70.09±3.88	75.65±2.91
Ionosphere	79.93±2.61	67.74±7.27	83.02±3.61	79.81±2.84	82.26±4.39	88.65±1.71	83.40±3.66	88.68±1.71
Sonar	53.22±4.74	43.23±3.85	68.06±8.93	50.97±6.60	64.52±6.23	68.06±9.95	72.90±4.90	68.06±9.95
Tic-Tac	54.44±3.69	35.28±2.78	58.96±2.89	34.51±2.24	60.07±2.76	35.21±2.29	64.03±3.43	35.21±2.29

Fig. 4 shows the total average accuracy in 10, 100, 1000 and 10000 epochs obtained from BELC and GDBP MLP in the test sets. As illustrated in Fig. 4, the higher accuracy in 10, 100 epochs is obtained from BELC and especially at the

lower epochs, BELC presents the higher accuracy. According to the Fig. 4, MLP needs many epochs to reach the results of BELC.

Fig. 5 presents a comparison between MLP and BELC based on average MSE at the four stop criterions. According to the Fig. 4 and Fig. 5, the higher accuracy and the lower MSE (especially at the lower epochs) mean that the performance of BELC is better than MLP in classification. And BELC can learn the patterns quickly. Finally Table 3 shows the maximum accuracy obtained from the two methods.

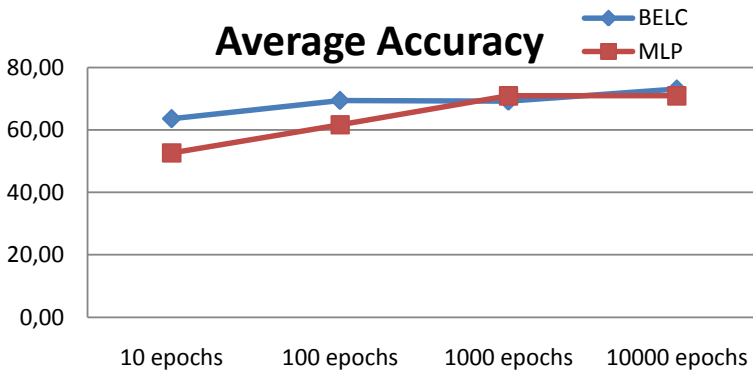

Fig. 4. the average accuracy comparison between BELC and MLP in UCI dataset classification problem with maximum epoch as stop criterion.

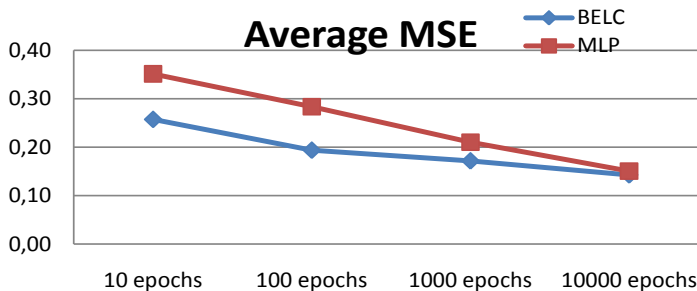

Fig. 5. The average MSE comparison between BELC and MLP in UCI dataset classification problem with maximum epoch as stop criterion.

Table 3. The maximum accuracy of classification results obtained from BELC and MLP during 10 runs.

<i>epochs</i>	10		100		1000		10000	
<i>Model</i>	BELC	MLP	BELC	MLP	BELC	MLP	BELC	MLP
Diabetes	80.90	79.13	76.52	75.65	77.39	81.47	78.3	81.78
Heart	73.20	78.05	85.37	87.80	75.61	81.22	85.37	87.80
Pima	70.43	68.70	74.78	71.30	82.60	75.65	76.50	80.87
Ionosphere	86.08	79.25	90.57	84.91	90.57	92.45	88.70	92.45
Sonar	61.30	51.56	80.65	64.52	74.19	90.32	80.65	90.32
Tic-Tac	63.89	63.89	64.58	37.50	67.36	40.28	70.14	40.28

4. Conclusions

In this paper we modified computational model of limbic system (LS) with novel configuration. The main modification introduced here was considering the functionality of amygdale as threshold logic unit. The modified model can be used in single class classification problems. In numerical studies, the proposed brain emotional learning based classifier (BELC) was utilized to classify 6 common data sets. And the comparisons between BELC and multilayer perceptron (MLP) with gradient descent backpropagation (GDBP) learning algorithm present the following conclusions: first, the performance of BELC was higher than MLP based on average and maximum test accuracy especially with 10 and 100 epochs stop criterion. Second, low computational complexity and fast training of BELC make it suitable for real time classification systems. Furthermore, the proposed model can be modified and utilized in other applications. We have improved the work and reported in [36] where an emotion inspired model has been proposed for multi input-multi output classification and chaotic time series prediction problems.

References

1. Morén J., *Emotion and Learning, A Computational Model of the Amygdala*, Lund University Cognitive Studies, 2002.
2. LeDoux J.E., *Emotion circuits in the brain*, Annual Review of Neuroscience, Vol. 23, 2000, pp.155-184.
3. LeDoux J.E., *The Emotional Brain*, Simon and Schuster, New York, 1996.
4. Rolls E.T., *Neurophysiology and functions of the primate amygdala*, In: *The Amygdala: Neurobiological Aspects of Emotion, Memory and Mental Dysfunction*, New York, Wiley-Liss, 1992, pp.143-165.
5. Cahill L., Haier R.J., Fallon J., *Amygdala activity at encoding correlated with long-term, free recall of emotional information*, Proceedings-National Academy of Science USA, Vol.93, 1996, pp. 8015-8021.
6. Bechara A, Damasio H., Damasio A.R. *Different contributions of the human amygdala and Ventromedial Prefrontal Cortex to Decision-Making*, Journal of Neuroscience, Vol.19, 1999, pp.5473–5481.
7. Balkenius C., Morén J. *Emotional learning: a computational model of amygdala*, Cybernetics and Systems, Vol. 32, 2001, pp. 611-636.
8. Morén J., Balkenius C. *A computational model of emotional learning in the amygdala*, In: *From Animals to Animats 6: Proceedings of the 6th International Conference on the Simulation of Adaptive Behaviour*, Meyer, J.A., A. Berthoz, D. Floreano, H.L. Roitblat and S.W. Wilson (Eds.). MIT Press, Cambridge, MA., USA, 2000, pp. 115-124.
9. Lucas C., Shahmirzadi D., Sheikholeslami N., *Introducing BELBIC: brain emotional learning based intelligent controller,* International Journal of Intelligence Automotive Soft Computing, Vol. 10, 2004, pp. 11-21.
10. Lucas C., *BELBIC and its industrial applications: towards embedded neuroemotional control codesign*, Integrated Systems, Design and Technology, Vol. 3, 2010, pp. 203-214.
11. Rouhani H., Jalili M., Araabi B.N., Eppler W., Lucas C. *Brain emotional learning based intelligent controller applied to neurofuzzy model of micro-heat exchanger*, Expert System and Application, Vol. 32, 2007, pp. 911-918.
12. Samadi M., Afzali-Kusha A., Lucas C. *Power management by brain emotional learning algorithm*, 7th International Conference on ASIC, 2007, pp. 78 – 81.
13. Daryabeigi E., Markadeh G.R.A., Lucas C. *Emotional controller (BELBIC) for electric drives — A review*, 36th Annual Conference on IEEE Industrial Electronics Society, 2010, pp. 2901 – 2907.
14. Chandra M., *Analytical Study of A Control Algorithm Based on Emotional Processing*, M.S. Dissertation, Indian Institute of Technology Kanpur, 2005.

15. Lucas C., Milasi R.M., Araabi B.N., Intelligent modeling and control of washing machine using Locally Linear Neuro-Fuzzy (LLNF), *Asian Journal of Control*, Vol. 8, 2006, pp. 393-400.
16. Jafarzadeh S., Mirheidari R., Motlagh M.R.J., Barkhordari M. Designing PID and BELBIC controllers in path tracking problem, *International Journal of Computers Communications & Control*, Vol. 3, 2008, pp. 343-348,.
17. Sadeghieh A., Sazgar H., Goodarzi K., Lucas C. Identification and real-time position control of a servo-hydraulic rotary actuator by means of a neurobiologically motivated algorithm, *ISA Transactions*, Vol. 51, 2012, pp. 208-219.
18. Khalilian M., Abedi, Zadeh A.D. Position control of hybrid stepper motor using brain emotional controller, *Energy Procedia*, Vol. 14, 2012, pp. 1998-2004.
19. Gholipour, Lucas, C.A.R.O., & Shahmirzadi, D.A.N.I.A.L. Predicting geomagnetic activity index by brain emotional learning, *WSEAS AIKED*, 3, 2004.
20. Lotfi E., Akbarzadeh-T, M.R., Supervised brain emotional learning, *IEEE Int. Joint Conf. on Neural Networks (IJCNN)*, 2012, pp. 1-6, doi: 0.1109/IJCNN.2012.6252391.
21. Lotfi E., Akbarzadeh-T., M.R., Adaptive Brain Emotional Decayed Learning for Online Prediction of Geomagnetic Activity Indices, *Neurocomputing*, doi: 10.1016/j.neucom.2013.02.040, 2013.
22. Lotfi E., Akbarzadeh-T. M. R. Emotional Brain-Inspired Adaptive Fuzzy Decayed Learning for Online Prediction Problems, In *Proc. IEEE International conference on fuzzy systems (FUZZ-IEEE 2013)*, July 7-10, 2013, Hyderabad, India.
23. Babaie T., Karimizandi, Lucas C. Learning based brain emotional intelligence as a new aspect for development of an alarm system, *Soft Comput.*, Vol. 12, 2008, pp. 857–873.
24. Caridakis G., Karpouzis, K., Kollias, S., User and context adaptive neural networks for emotion recognition, *Neurocomputing*, Vol.71, 13, 2008, pp.2553-2562.
25. Mermillod M., Bonin, P., Mondillon, L., Alleysson, D., Vermeulen, N. Coarse scales are sufficient for efficient categorization of emotional facial expressions: Evidence from neural computation, *Neurocomputing*, Vol.73, 13, 2010, pp.2522-2531.
26. Wang H., Kongqiao Wang, Affective interaction based on person-independent facial expression space, *Neurocomputing*, Vol.71, 10, 2008, pp.1889-1901.
27. Mustafa M.B., Aionon, R.N., Zainuddin, R., Don, Z.M., Knowles, G., Mokhtar, S. Prosodic Analysis And Modelling For Malay Emotional

- Speech Synthesis, Malaysian Journal of Computer Science, Vol.23, 2, 2010.
28. Daglarli E., Temeltas H., Yesiloglu M., Behavioral task processing for cognitive robots using artificial emotions, Neurocomputing, Vol.72, 13, 2009, pp. 2835-2844.
 29. Fragopanagos N., Taylor J.G. Modelling the interaction of attention and emotion, Neurocomputing, 69(16), 2006, pp.1977-1983.
 30. CaÑamero, Lola, Emotions and adaptation in autonomous agents: a design perspective, Cybernetics & Systems, Vol.32, 5, 2001, pp.507-529.
 31. Kitamura, Tadashi, Kuniko Ono. An architecture of emotion-based behavior selection for mobile robots, Cybernetics & Systems Vol.32, 6 2001, pp. 671-690.
 32. Ventura R., Pinto-Ferreira C. Responding efficiently to relevant stimuli using an emotion-based agent architecture, Neurocomputing, Vol.72, 13, 2009, pp.2923-2930.
 33. Wang H., Kongqiao Wang, 2008, Affective interaction based on person-independent facial expression space, Neurocomputing, Vol.71, 10, pp.1889-1901.
 34. Ventura R., Pinto-Ferreira C. Responding efficiently to relevant stimuli using an emotion-based agent architecture, Neurocomputing, vol.72, 13, 2009, pp.2923-2930.
 35. Hagan M.T., Demuth H.B., Beale M.H., Neural Network Design, Boston, MA: PWS Publishing, 1996.
 36. Lotfi E., Akbarzadeh-T. M. R. Brain Emotional Learning Based Pattern Recognizer, Cybernetics & Systems, 2013, doi: 10.1080/01969722.2013.789652.

Klassifikasiya məsələlərinin həlli üçün emosional beynin riyazi modeli

Ehsan Lotfi

XÜLASƏ

Son zamanlar məmülilərin beyninin emosional təliminin müxtəlif riyazi modelləri idarəetmə və proqnozlaşdırmanın müxtəlif praktiki məsələlərinin həllində uğurla tətbiq olunur. Bu məqalədə beynin emosional təliminə əsaslanan klassifikator təqdim olunur. Bu klassifikatorun fərqli cəhəti ondan ibarətdir ki, modeldə tənziq aktivləşdirmə funksiyasından istifadə olunmuşdur. Təklif olunan modellə 6 verilənlər yığımını klassifikasiya edən çoxqatlı perseptron arasında ədədi müqayisə aparılmışdır. Ədədi eksperimentlər göstərir ki, təklif edilən model daha yüksək dəqiqlikli nəticələri daha sadə hesablamalar nəticəsində almağa imkan verir və bir sıra tətbiqi məsələlərin həllində istifadə oluna bilər.

Açar sözlər: Amygdala, hesablama modeli, BELBİC, online klassifikasiya.

Математическое моделирование эмоционального мозга для задач классификации

Эхсан Лотфи

РЕЗЮМЕ

В последнее время всевозможные модели для эмоционального обучения мозга (ЭОМ) млекопитающих были успешно использованы в конкретных приложениях проблем управления и прогнозирования. В данной работе представлен классификатор на основе ЭОМ. Отличительной особенностью этого классификатора является применение функции активации *tansig* в модели. В численных исследованиях, приведены различные сравнения между предложенным подходом и многослойным перцептроном для классификации 6 наборов данных. Согласно численным исследованиям предложенный подход показывает более высокую точность и нижнюю вычислительную сложность в классификации одного класса и может быть использовано проблем классификации в реальном времени.

Ключевые слова: Amygdala, вычислительная модель, BELVIC, онлайн классификация.